

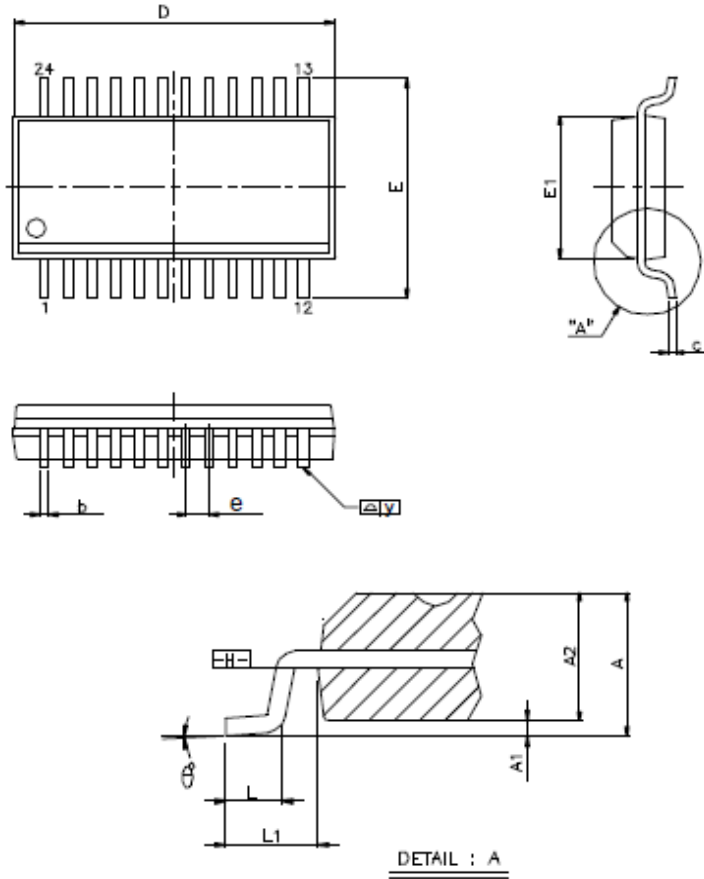

24L SSOP(150mil) Package Outline :



Symbol	Dimension in mm			Dimension in inch		
	Min	Nom	Max	Min	Nom	Max
A	—	—	1.75	—	—	0.069
A1	0.10	—	0.25	0.004	—	0.010
A2	—	—	1.50	—	—	0.059
b	0.20	—	0.30	0.008	—	0.012
c	0.18	—	0.25	0.007	—	0.01
D	8.56	—	8.76	0.337	—	0.345
E	5.79	—	6.20	0.228	—	0.244
E1	3.80	—	4.00	0.150	—	0.157
e	—	0.635	—	—	0.025	—
L	0.41	—	1.27	0.016	—	0.050
L1	—	1.05	—	—	0.041	—
y	—	0.10	—	—	0.004	—
θ	0°	—	8°	0°	—	8°

Note :

1. Dimension D & E1 do not include mold protrusion.
2. Dimension b does not include dambar protrusion.